



- NOTES:
- MATERIAL:
 - HOUSING: THERMOPLASTIC, HIGH TEMP.,UL94V-0
 - CONTACT: COPPER ALLOY
 - SHELL: STAINLESS STEEL
 - FINISH:
 - CONTACT: 50u" MIN. NICKEL UNDERPLATING OVERALL.
0:10u" MIN GOLD PLATING ON CONTACT AREA
GOLD FLASH PLATING ON SOLDER AREA
1:1u" MIN GOLD PLATING ON CONTACT AREA
GOLD FLASH PLATING ON SOLDER AREA
 - SHELL:10u"MIN NICKEL UNDER PLATING OVERALL,
N:10u"MIN MATT TIN PLATING OVERALL
 - REFLOW SOLDER CAPABLE TO 260°C PER ACES SPEC.
 - SPEC. PLS. REFER TO PS-51363-XXXX-XXX
 - PACKAGE PLS. REFER TO 51363-XXXX-XX-TRP.
 - PART NUMBER

| | | | | | |
|-------------------|---------|--------|---------------|--------------|-------------------|
| 51363-XXX X X-XXX | | Others | HOUSING COLOR | HALOGEN FREE | PACKAGE |
| CKTS | PLATING | 001 | BLACK | HF | 51363-XXXX-XX-TRP |
| | | 002 | NATURAL | HF | 51363-XXXX-XX-TRP |

Packing: 7:Tape & Reel with Cover

PLATING: 0:10u" MIN GOLD ON CONTACT AREA
1:1u" MIN GOLD ON CONTACT AREA

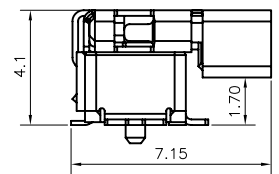
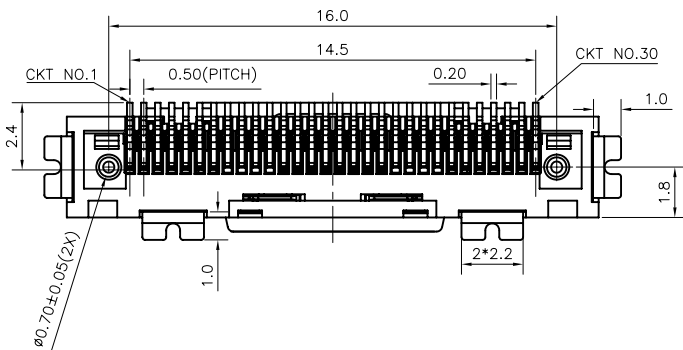
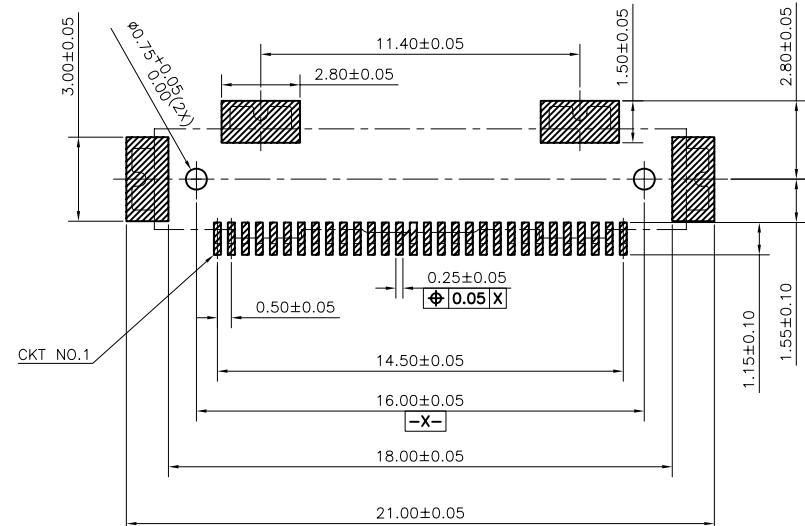
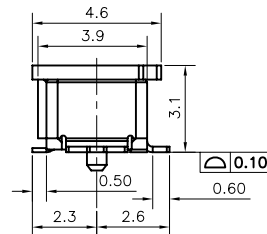
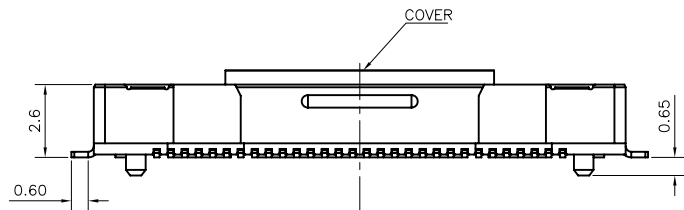
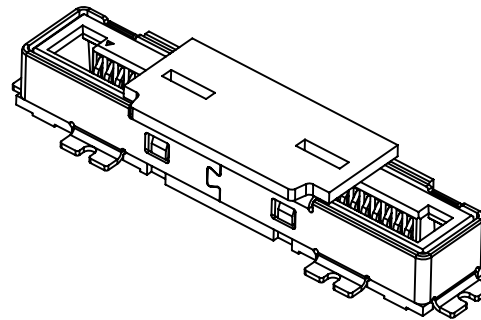
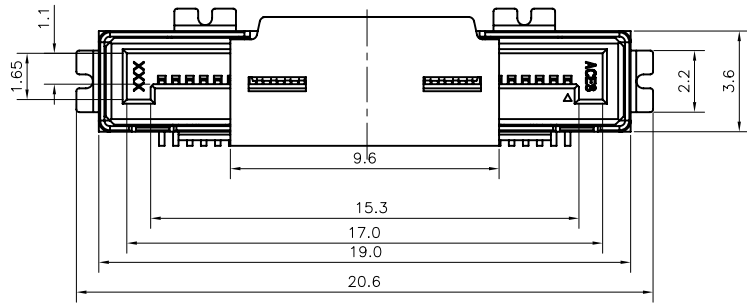

MATING VIEW

30 Pin

| | | | |
|---|---|---|--|
| 一般公差 TOLERANCES X ±0.50 XX ±0.15 X ±0.25 XXX ±0.10 ANGLES ±2° | | 宏致電子股份有限公司 Aces Electronics Co.,Ltd. | |
| 檢驗尺寸標示 SYMBOLS ⊕ ⊗ INDICATE CLASSIFICATION DIMENSION ⊕ MARK IS CRITICAL DIM. ⊗ MARK IS MAJOR DIM. | 品名 (TITLE) 0.5 mm PITCH LVDS CONN. SMT S/R S/T TYPE | 製圖 (DR) 17/08/31 CHENYA | 審核 (CHKD) BRAVE |
| 圖號 (DWG NO.) 51363-XXXX-XXX | | 核准 (APPD) FRANK | |
| 表面處理 (FINISH) | 比例 (SCALE) 5:1 | 單位 (UNITS) mm | 張數 (SHEET) 1 OF 1 圖號 (DWG NO.) 51363-XXXX-XXX |